

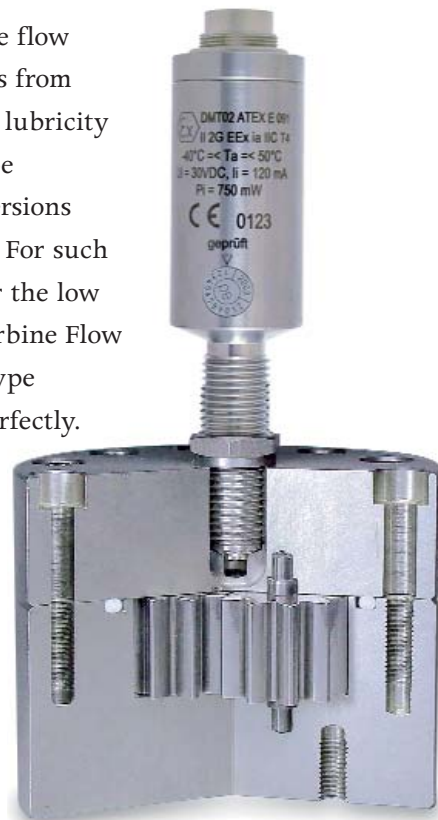

ZHM Series Gear Flow Meters (PD Meters)

Application

Gear flow meters are suitable for the precise flow measurement of various fluids of viscosities from 5 up to 25,000 mm²/s. Providing sufficient lubricity of the fluid, the small gear flow meters type ZHM 01/1 and 02 as well as ball bearing versions may also be used for fluids below 5 mm²/s. For such applications special specifications apply for the low flow range and linearity. Generally, our Turbine Flow Meters, type HM, and Micro Flow Meter type LFM 10 will handle low-viscosity fluids perfectly.



Typical Applications

- Waterborne paints, clear coatings, 2-component paints, highly-filled metal paints and softfeel paints
Special versions with excellent purging qualities and low pressure drop figures are available for paint applications (see page 3).
- Coating wax, glues, PVC, epoxy resin, highly-filled and abrasive fluids
- Polyol- and isocyanate
- Oil and fat (also fluid food and cosmetics)
Heated versions are available on request
- Hydraulic oil
For oils without abrasive particles gear flow meters ZHM 06 and 07 are available with stainless ball-bearings
- Off-shore applications
Special meters with high-pressure connectors up to 690 bar

Special Requirements

Dynamic measurements

The output frequency of gear flow meters is very high resulting in very good resolution and suitability for pulsating flow rates.

Reverse-flow detection and pulse multiplication

Fitting a twin pickup, reverse flow can be detected. Furthermore, pulse rates can be multiplied for faster and more accurate evaluation.

Ex-protection Exia IIC T6/T4

Ex-protected pickups and amplifiers are available for zone 1, zone 0 subject to individual inspection. In addition, intrinsically-safe supply units may be provided.

Resistance to high voltage from 50 kV up to 120 kV

Fibre-optical pickups (type FOP) are available for electrostatical painting systems.

KEM evaluation electronics for monitoring, control and 2-component applications

FAU frequency to analogue converter • MCM 400 display • MCM 200 evaluation system (also with printer)

Principle and Design

Gear flow meters are positive displacement meters, similar in design to a gear pump. The measuring medium rotates two gears, which are engaged with minimum play. The medium is forced along through closed measuring chambers between gears and housing. The gears, which run idle, lose no power. The RPM of the gears is in proportion with the instantaneous flow rate and is precisely detected by integral pickups through the body of the meter without contacting the fluid. Pulses per volume unit will finally serve the evaluation (pls. also refer to pickup and amplifier datasheets).

K-Factor and Linearity

The K-factor (no. of pulses per litre) is almost constant over a wide range. Even with low flow rates measuring results are very precise as leakage is kept down to a minimum by very close production tolerances. A linearity error of $\pm 0.5\%$ of instant. value can be easily maintained for a flow ratio of 1:20 and viscosities above 15 mm²/s. Accuracy improves as viscosity increases. The linearity error will decrease to $\pm 0.25\%$ of instant. flow for viscosities from 50 to over 10,000 mm²/s.

The individual K-factor and linearity for each ZHM is determined during calibration and documented for the user in calibration records. When calibrating we consider as much as possible operating viscosities and customer's specifications.



Gear Flow Meters for Paints

Rapid colour changes and low solvent consumption are the major quality requirements with state-of-the-art paint-spraying systems. The flow meter as part of the system must contribute to meet these requirements. The meter has to be of a low weight to enable an installation close to the spray gun, and it must facilitate complete purging within a few seconds.

We designed our light-weight meter type ZHM 02/1 LW to meet these particular requirements. The weight was reduced by 50% compared with standard ZHM 02/1 and dead space was eliminated by patented construction features. The new design found the approval of most major automotive companies in world wide applications in paint-spraying systems.



ZHM...LW

ZHM...CT

ZHM...CT – A further development of lightweight flow meters

The new ZHM...CT series continues the development of paint flow meters combining the characteristics of the light-weight series and a new *cartridge design* as well as an improved *measuring kit*.

The cartridge design reduces the total weight of the flow meter down to a mere 550 g. Thanks to this reduction the ZHM...CT may be installed right behind the spray gun without adverse effects on the dynamic properties and positioning accuracy of the spray robot.

The newly designed measuring kit provides a high resolution and allows for a precise measurement over a measuring range which would usually require two flow meters.

The ZHM...CT is suitable to handle base paints, fillers, transparent and waterborne coatings perfectly. As a major advantage over other measuring systems the fibre-optic signal transmission from the ZHM...CT allows for the use in electrostatic spraying systems.

A separate datasheet on the ZHM...CT series is available on request.

Technical Data

ZHM type	Meas. range, ltr/min			K-factor, pulses/ltr ²)		Frequency range, Hz		
				single pickup	twin pickup	single pickup		
ZHM 01	0.005	to	1	41,000	82,000	3.4	to	683
ZHM 01/1 ¹⁾	0.005	to	2	26,500	53,000	2.2	to	883
ZHM 01/2 ¹⁾	0.02	to	3	14,000	28,000	4.6	to	700
ZHM 02/1 ¹⁾	0.05	to	2	8,200	16,400	6.8	to	273
ZHM 02 ¹⁾	0.1	to	7	4,200	8,400	7	to	490
ZHM 03	0.5	to	25	1,740	3,480	14	to	725
ZHM 04	0.5	to	70	475	950	4	to	554
ZHM 05	5	to	150	134	268	11	to	335
ZHM 06/1	5	to	250	106	212	8.8	to	442
ZHM 06	20	to	500	53	106	18	to	442
ZHM 07	50	to	1,000	24	48	20	to	400

Specifications apply when using amplifier type VTE*/P and for viscosities from 30 mm²/s onwards.

1) also available as weight-reduced version for paints (cf. page 3)

2) Average values, individual K-factors can be taken from calibration records supplied with each ZHM.

Materials

Housing:standard: stainless steel as per DIN 1.4305/AISI 303

.....special: DIN 1.4404/AISI 316 L or DIN 1.4571/AISI 316 Ti

gears:stainless steel as per DIN 1.4122/AISI 303 or 1.4460/AISI 329 (special)

Shafts, bearing bushes:tungsten carbide, ball bearings on request

Seals:O-rings: viton, teflon, NBR or EPDM (for brake fluid)

Pickups, Amplifiers and Temperature

- VTE*/P : carrier-frequency amplifier with single pickup, for fluids up to +150 °C
- VTM: local display unit with integral frequency- and analogue output, for fluids up to +150 °C
- TD*: carrier-frequency amplifier with twin pickup, for fluids up to +80 °C
- VTQ: quadruple carrier-frequency pickup an amplifier with integral divider, for fluids up to +80 °C
- FOP: fibre-optical amplifier for electrostatic environment, fluids up to +60 °C
- IF*/VIEG: inductive pickup and amplifier for fluids up to +180 °C

Details on pickups available in separate datasheets.

Connections and Nominal Pressure

ZHM type	Connections	Max.pressure
ZHM 01 to ZHM 03	female threads for Ermeto-fittings GE 6-PSM	PN 630 bar
ZHM 04	female threads for Ermeto-fittings GE 14-PSM	PN 630 bar
ZHM 05	female threads for Ermeto-fittings GE 25-PSM	PN 400 bar
ZHM 06/1, 06	bores for SAE flanges 1 1/4", PSI 6000	PN 400 bar
ZHM 07, 07 KL	bores for SAE flanges 1 1/2", PSI 6000	PN 400 bar

Ermeto fittings, SAE connectors and higher pressure rates available on request.

Dimensional drawings (mm)

ZHM 01 to ZHM 05

Side view

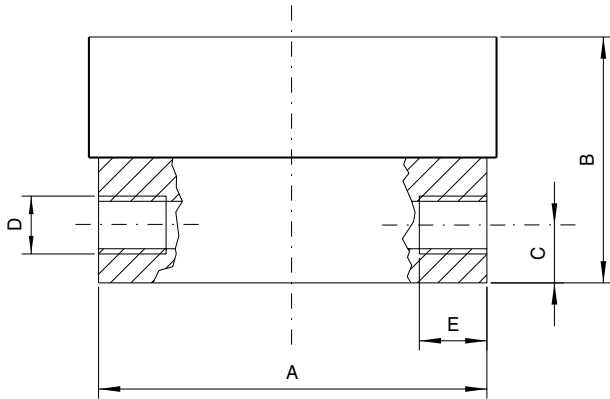

metric threads

Type	A Ø	B	C	D	E
ZHM 01	72.0	41	10.5	M12 x 1.5	14
ZHM 01/1	72.0	41	10.5	M12 x 1.5	14
ZHM 01/2	72.0	50	10.5	M12 x 1.5	14
ZHM 02/1	80.5	51	12.0	M12 x 1.5	14
ZHM 02	80.5	55	12.0	M12 x 1.5	14
ZHM 03	80.5	67	12.0	M12 x 1.5	14
ZHM 04	121.0	96	17.0	M20 x 1.5	18
ZHM 05	170.0	133	22.5	M33 x 2.0	18

inch threads

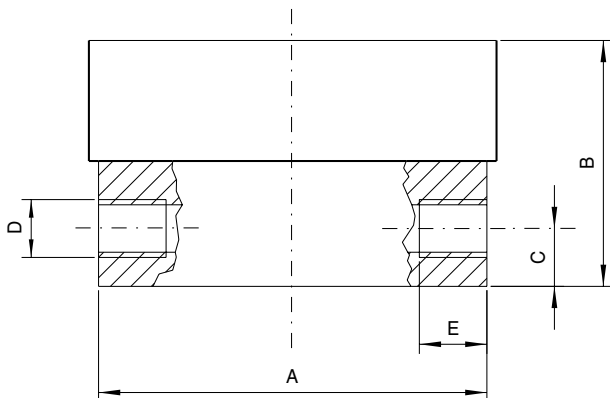

Type	A Ø	B	C	D	E
ZHM 01	72.0	41	10.5	G 1/4"	14
ZHM 01/1	72.0	41	12.0	G 1/4"	14
ZHM 01/2	72.0	50	12.0	G 1/4"	14
ZHM 02/1	80.5	51	12.0	G 1/4"	14
ZHM 02	80.5	55	12.0	G 1/4"	14
ZHM 03	80.5	67	12.0	G 1/4"	16
ZHM 04	121.0	96	17.0	G 1/2"	18

Bottom view

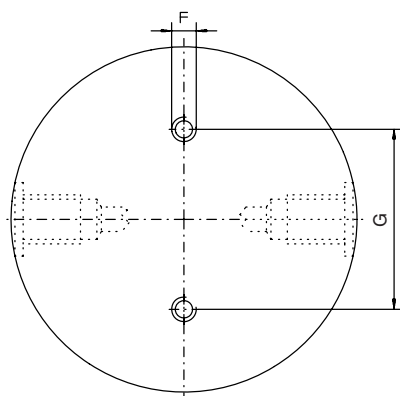

Type	G	F
ZHM 01	44	M6
ZHM 01/1	44	M6
ZHM 01/2	44	M6
ZHM 02/1	44	M6
ZHM 02	44	M6
ZHM 03	44	M6
ZHM 04	60	M6
ZHM 05	100	M8

ZHM 06 to ZHM 07

Side view

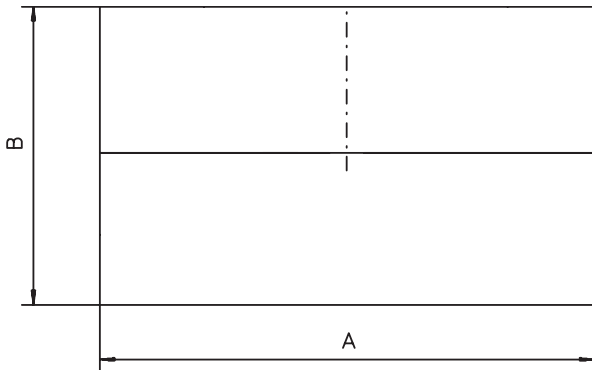

Type	A	B
ZHM 06/1 KL	188	138
ZHM 06 KL	188	180
ZHM 06	188	180
ZHM 07 KL	232	200
ZHM 07	232	220

bottom view ZHM 06

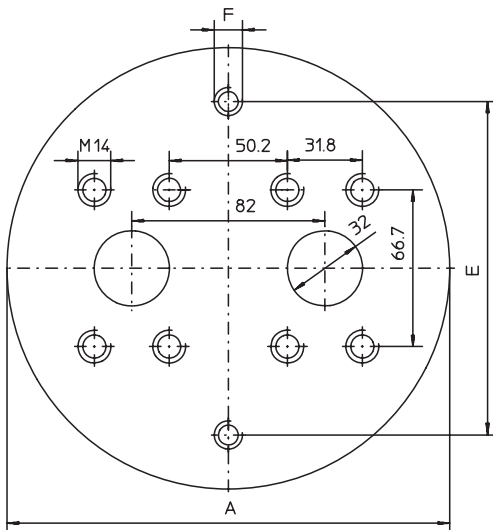

Type	A	E	F
ZHM 06/1 KL	188	142	M12
ZHM 06 KL	188	142	M12
ZHM 06	188	142	M12

Connections only for bottom entry.

bottom view ZHM 07

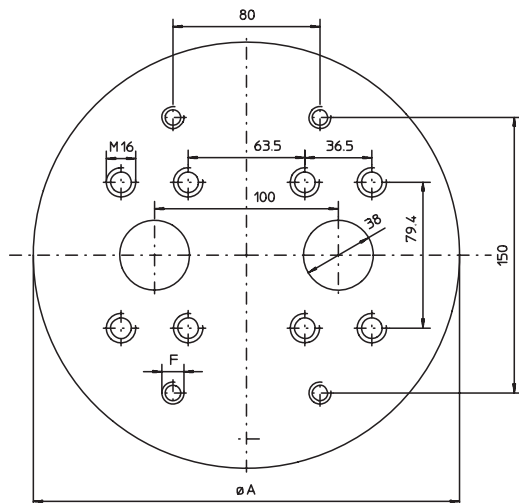

Type	A	F
ZHM 07	232	M12

Connections only for bottom entry.

Pressure Drop

ZHM 01/1
pressure drop in bar

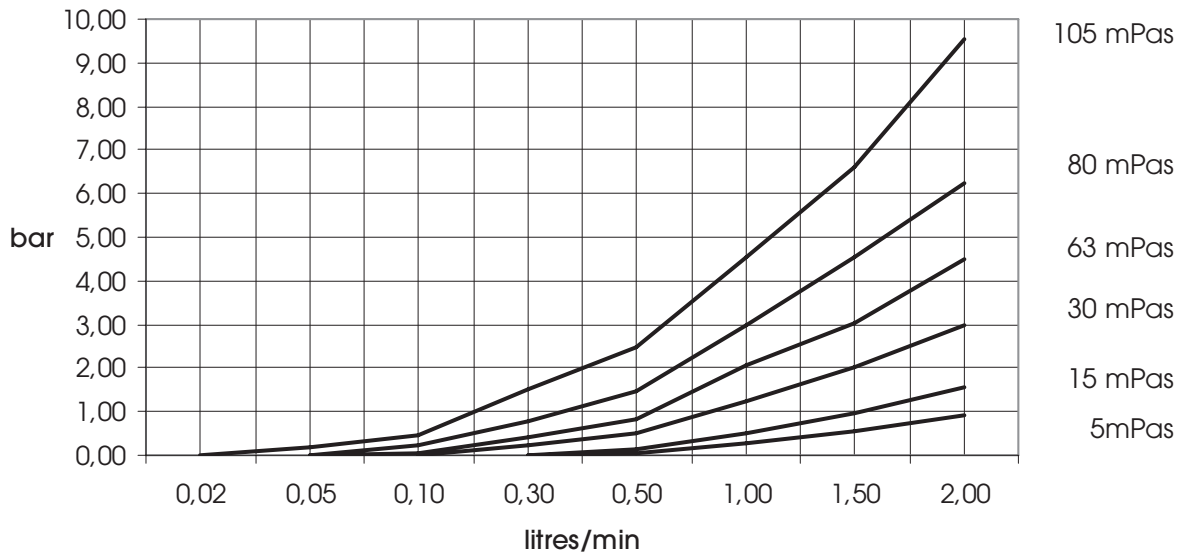

ZHM 01/2
pressure drop in bar

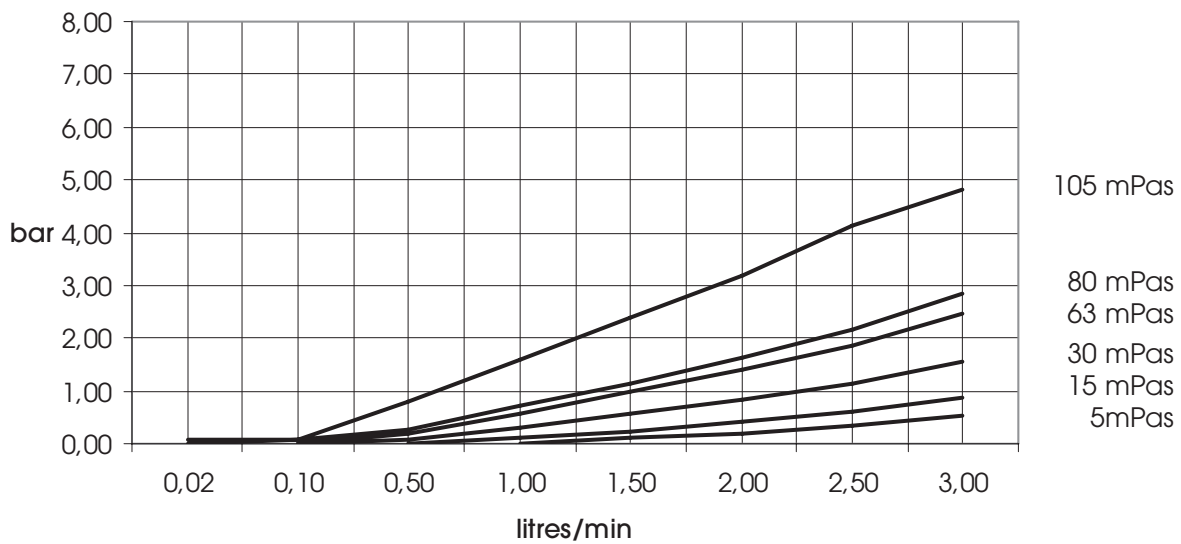

Pressure Drop

ZHM 01 to ZHM 02

pressure drop in bar

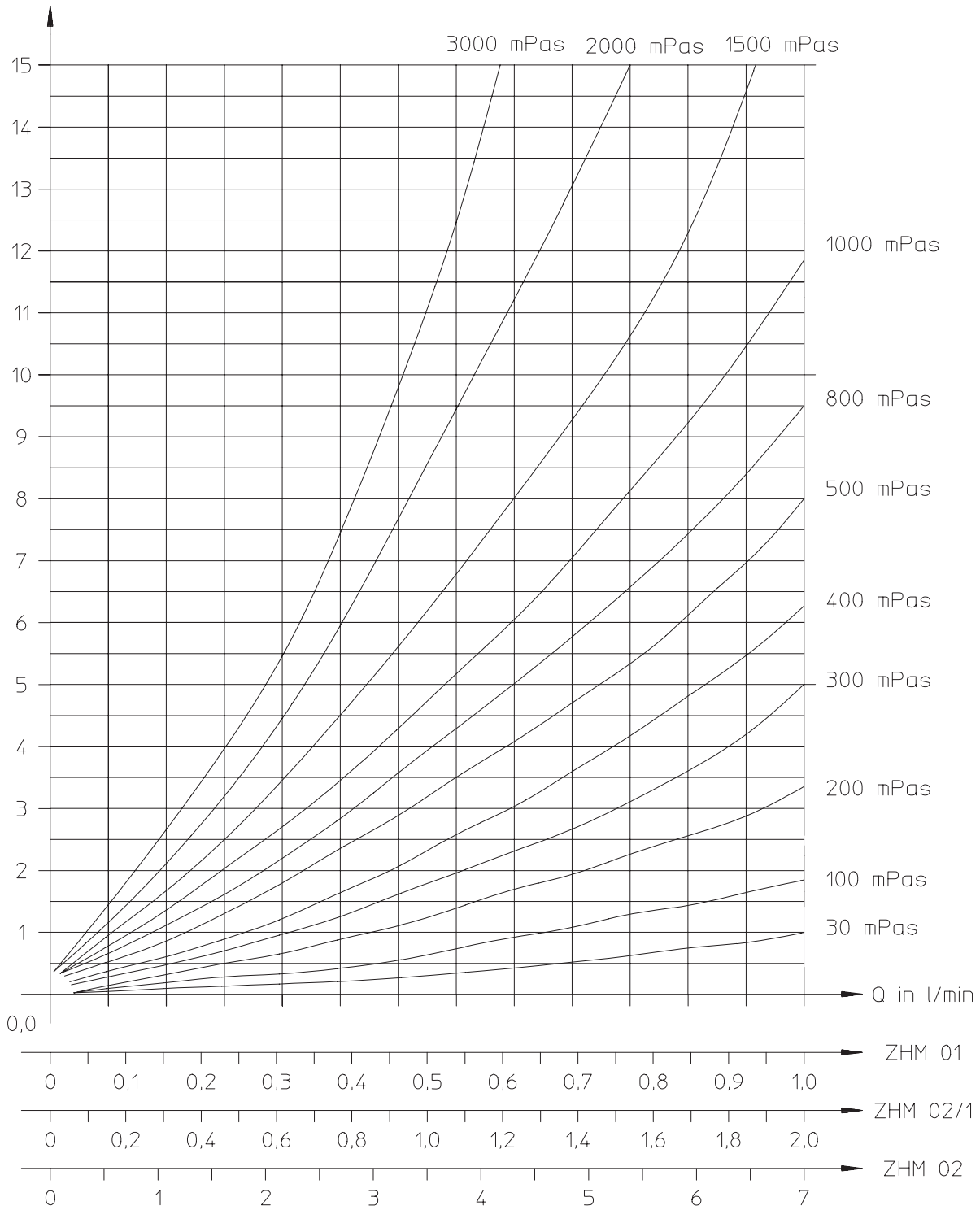

ZHM 03 to ZHM 05

pressure drop in bar

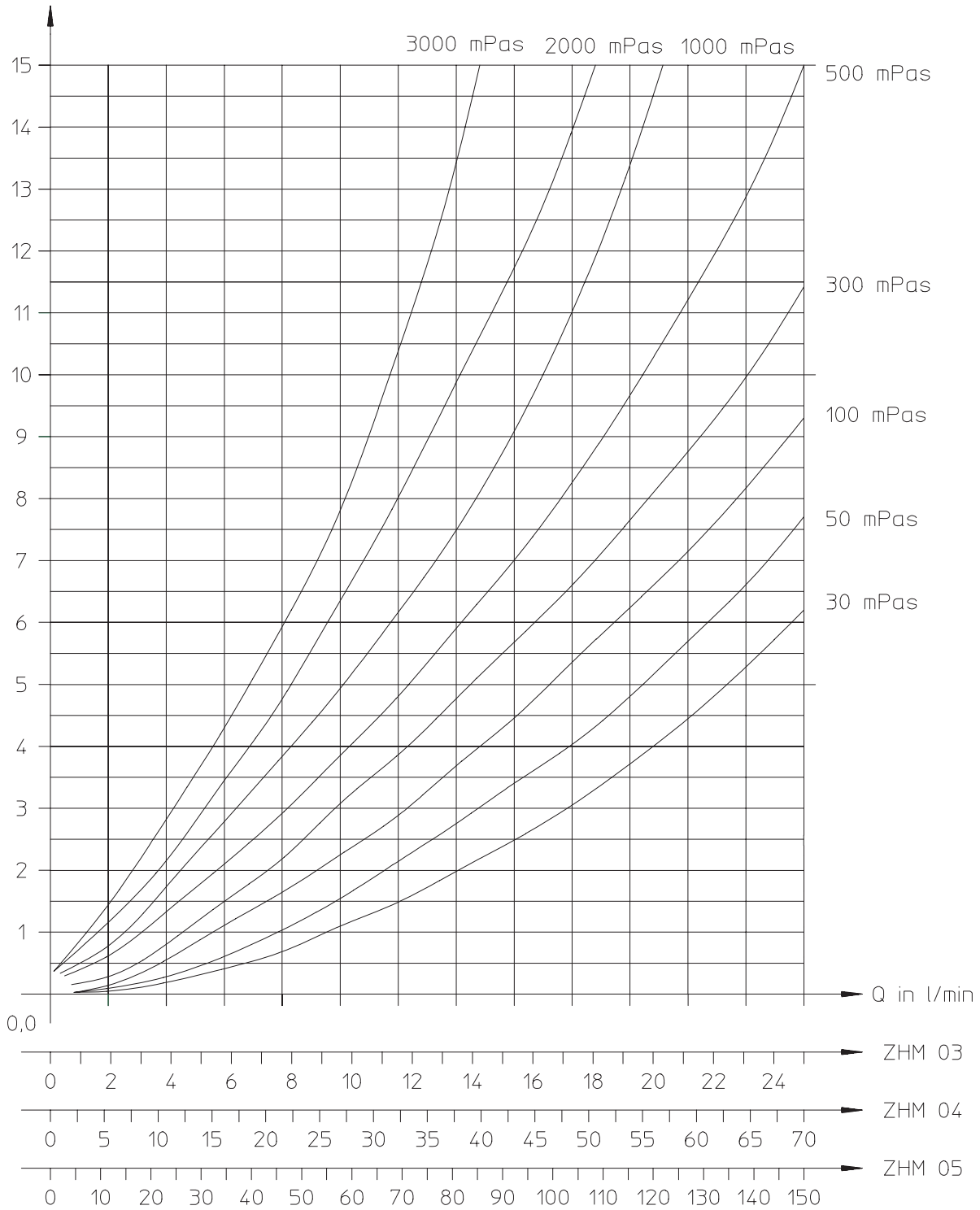

Pressure Drop

ZHM 06/1 KL, ZHM 06 KL

pressure drop in bar

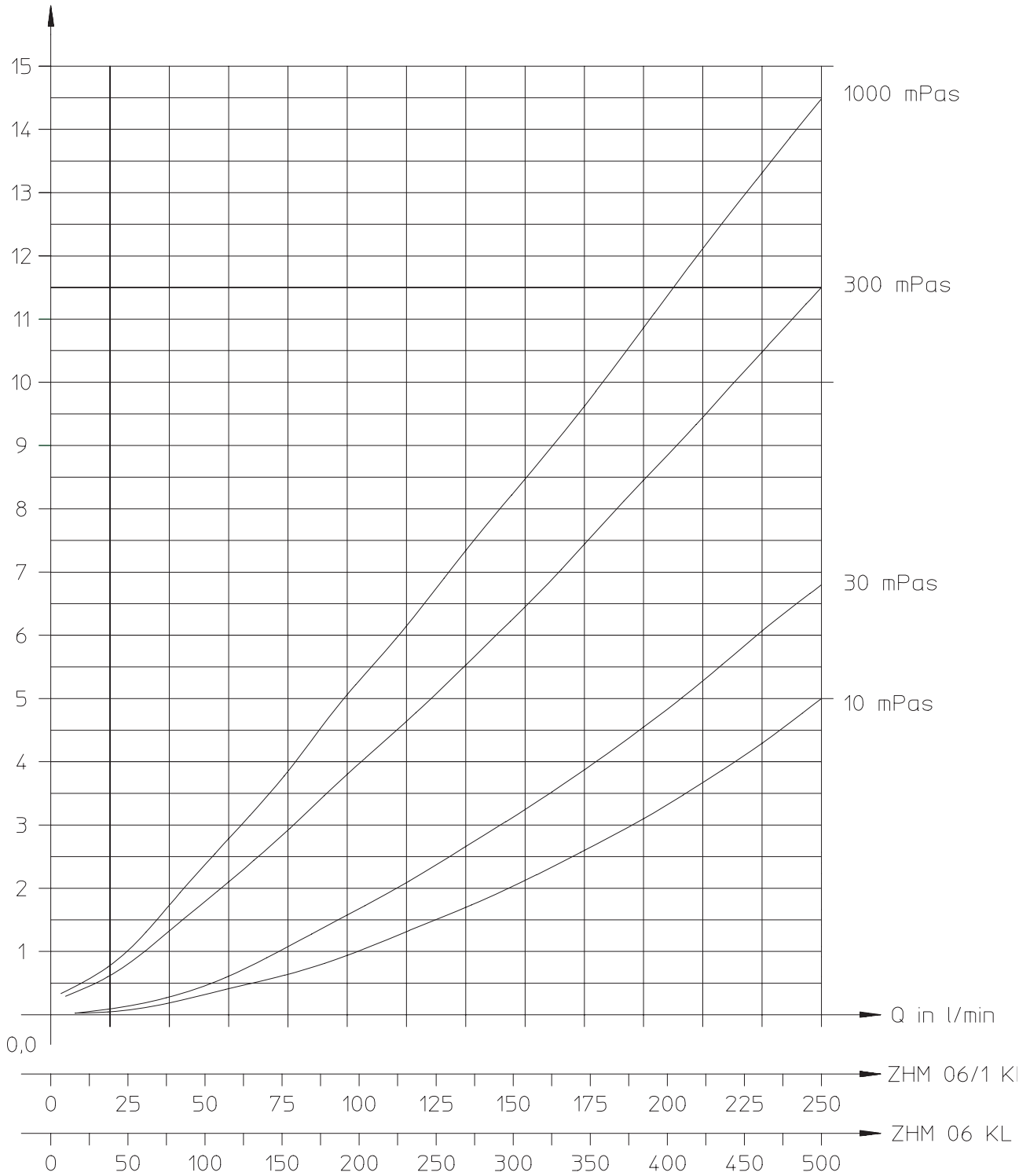

ZHM 06, ZHM 07

pressure drop in bar

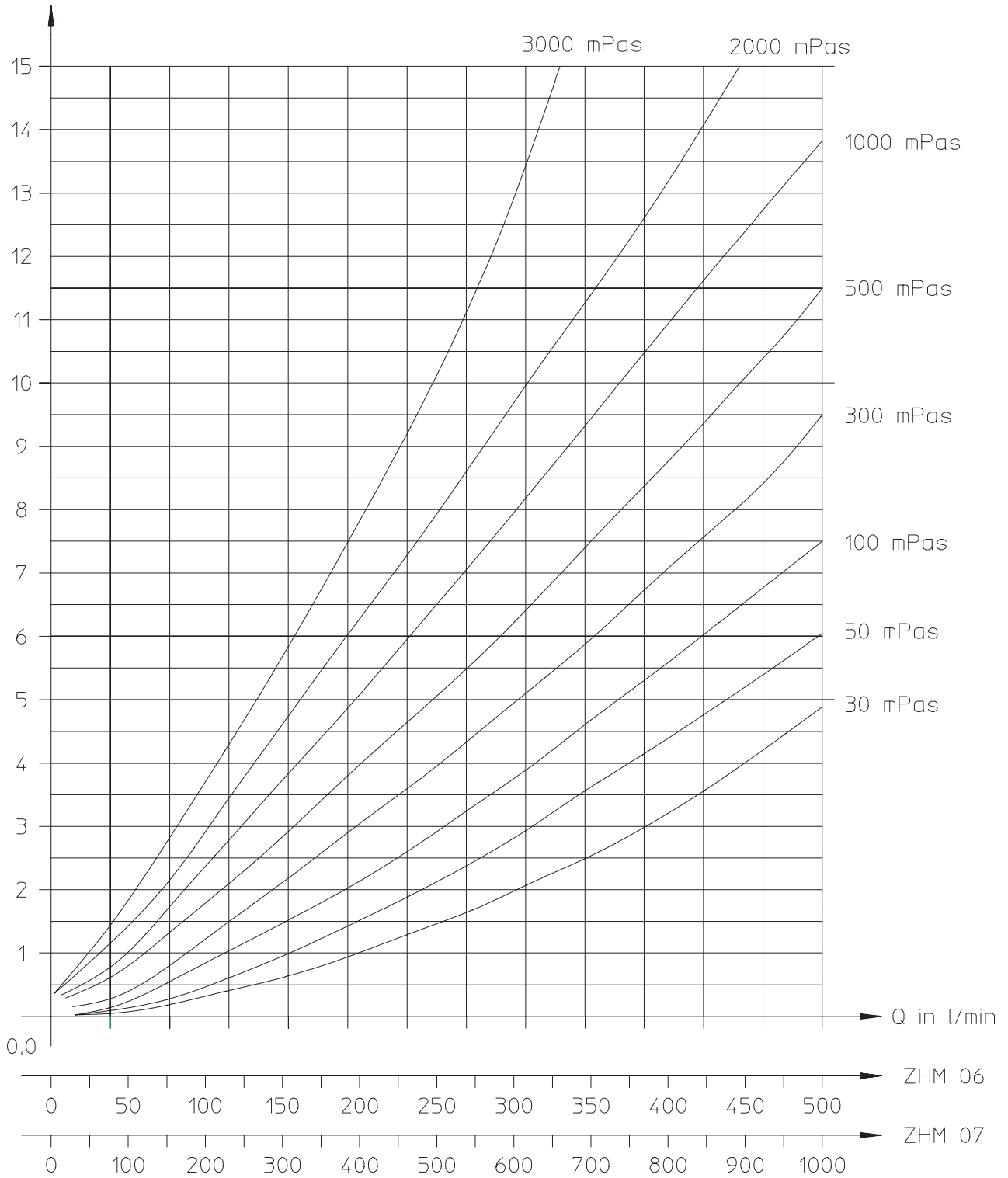

K-Factors at different viscosities

